



INSTALLATION INSTRUCTIONS

Split System Heat Pump & Air Conditioner

13-14 SEER

1.5-5 Tons

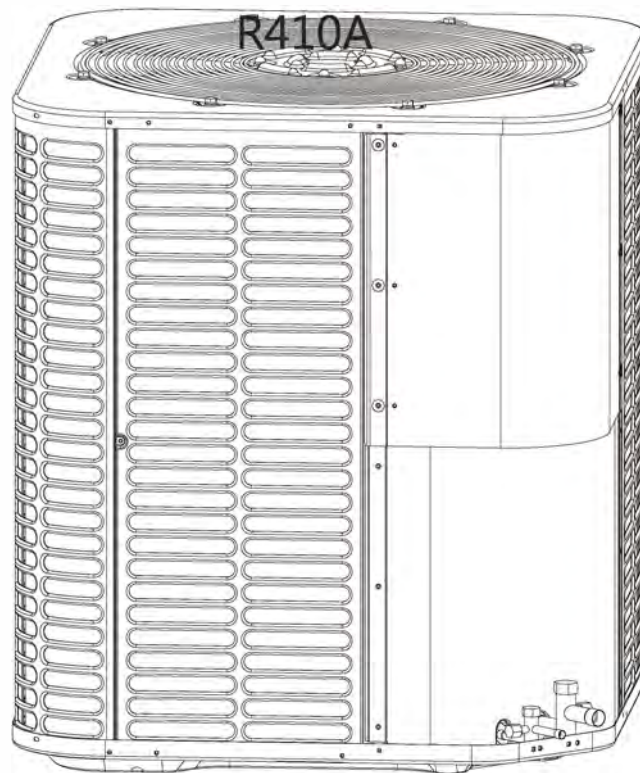

RECOGNIZE THIS SYMBOL AS AN INDICATION OF IMPORTANT SAFETY INFORMATION

WARNING

These instructions are intended as an aid to qualified licensed service personnel for proper installation, adjustment and operation of this unit. Read these instructions thoroughly before attempting installation or operation. Failure to follow these instructions may result in improper installation, adjustment, service or maintenance possibly resulting in fire, electrical shock, property damage, personal injury or death.



Unitary Small AC
AHRI Standard 210/240
Certification applies only when the complete system
is listed with AHRI.



Unitary Small HP
AHRI Standard 210/240
Certification applies only when the complete system
is listed with AHRI.



DO NOT DESTROY THIS MANUAL

Please read carefully and keep in a safe place for future reference by a serviceman.

Outdoor Units

1. Dimensions	3.
2. Service Space	4.
3. Piping Diagrams	5.
4. Wiring Diagrams	7.
5. Electric Characteristics	8.
6. Operation Limits	9

1. Dimensions

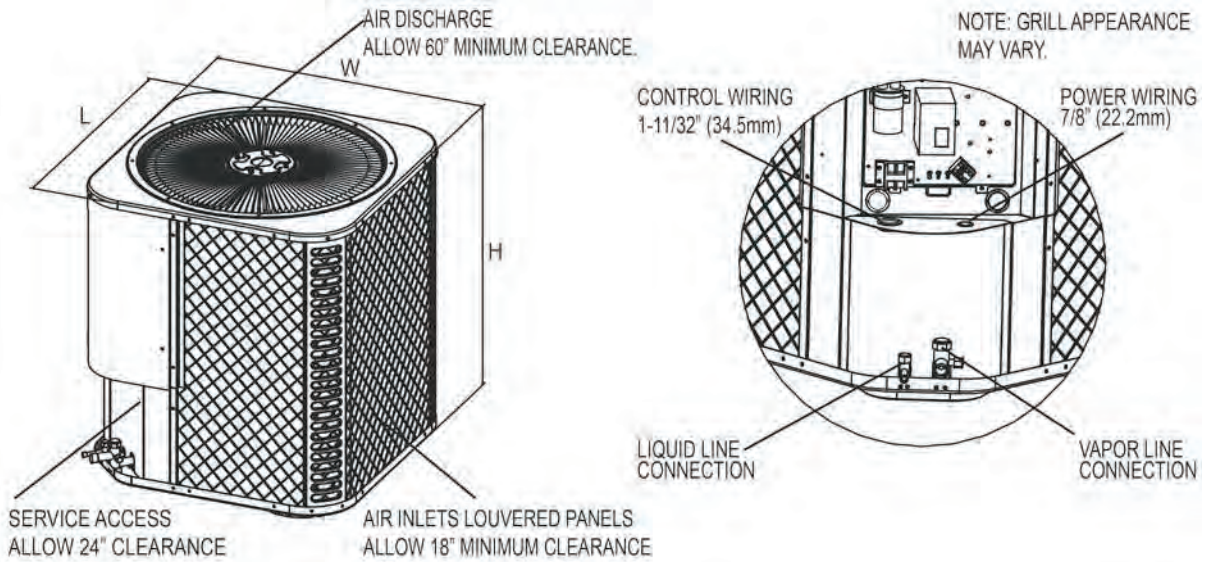

Unit Model	Dimensions (Inches)			Refrigerant Connection Service Valve Size	
	"H" in [mm]	"W" in [mm]	"L" in [mm]	Liquid in	Vapor in
18K	25 [633]	21-4/5 [554]	21-4/5 [554]	3/8	3/4
24K	25 [633]	21-4/5 [554]	21-4/5 [554]	3/8	3/4
30K	25 [633]	21-4/5 [554]	21-4/5 [554]	3/8	3/4
36K	25 [633]	29-1/7 [740]	29-1/7 [740]	3/8	3/4
42K	32-7/8 [835]	29-1/7 [740]	29-1/7 [740]	3/8	3/4
48K	32-7/8 [835]	29-1/7 [740]	29-1/7 [740]	3/8	7/8
60K	32-7/8 [835]	29-1/7 [740]	29-1/7 [740]	3/8	7/8

2. Service Space

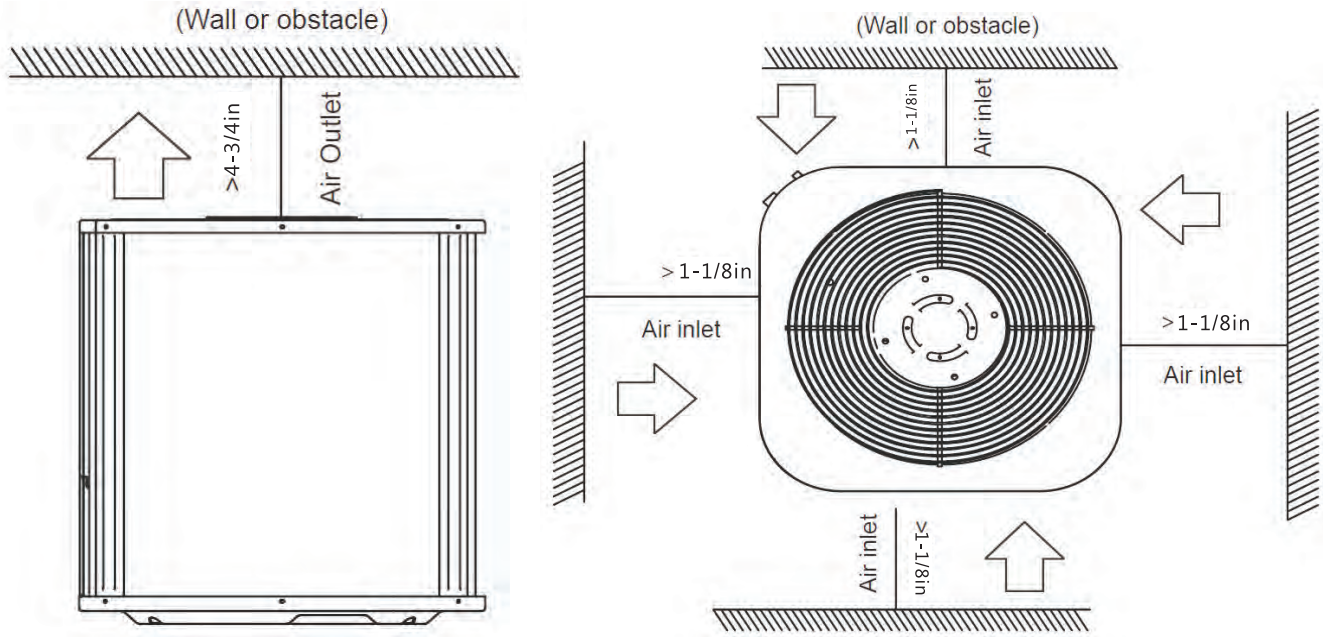

3. Piping Diagrams

Applicable for 18k, 24k, 30k, 36k cooling only type

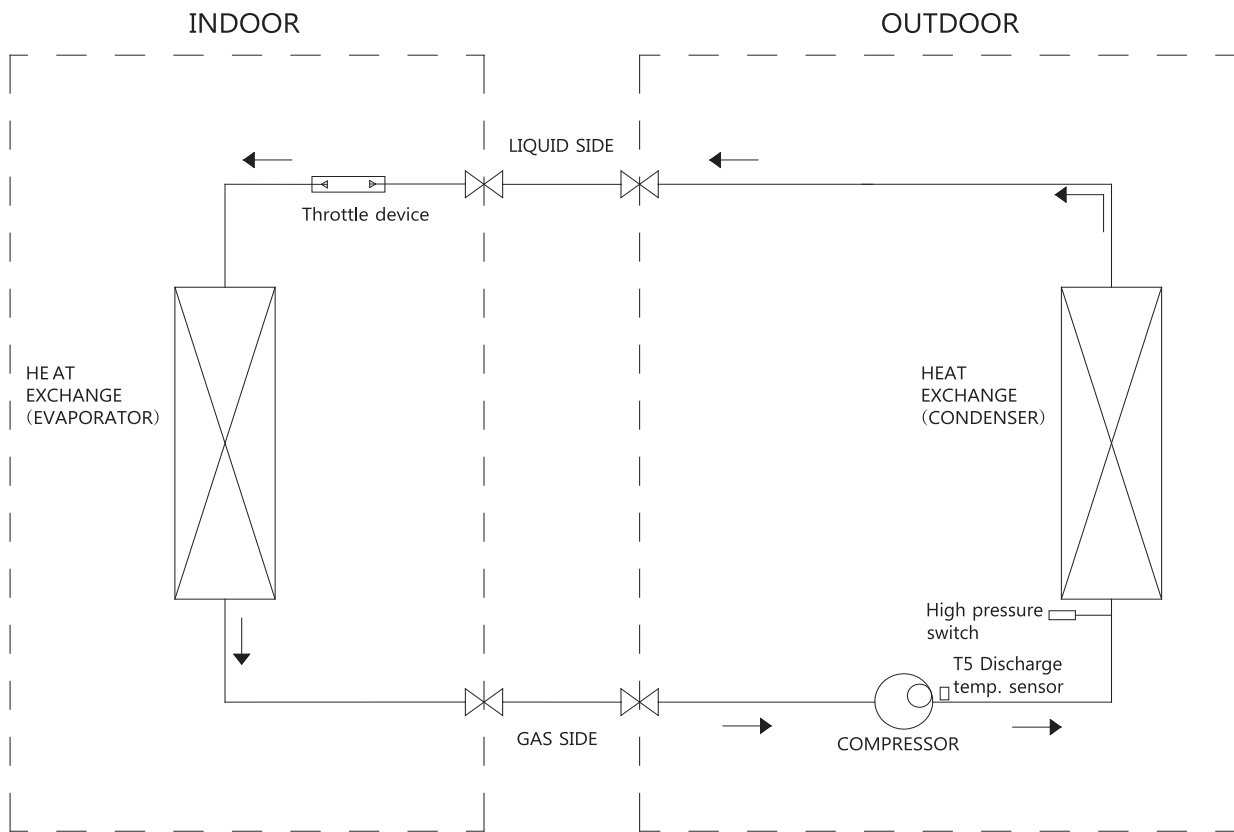

Applicable for 18k, 24k, 30k, 36k cooling & heating type

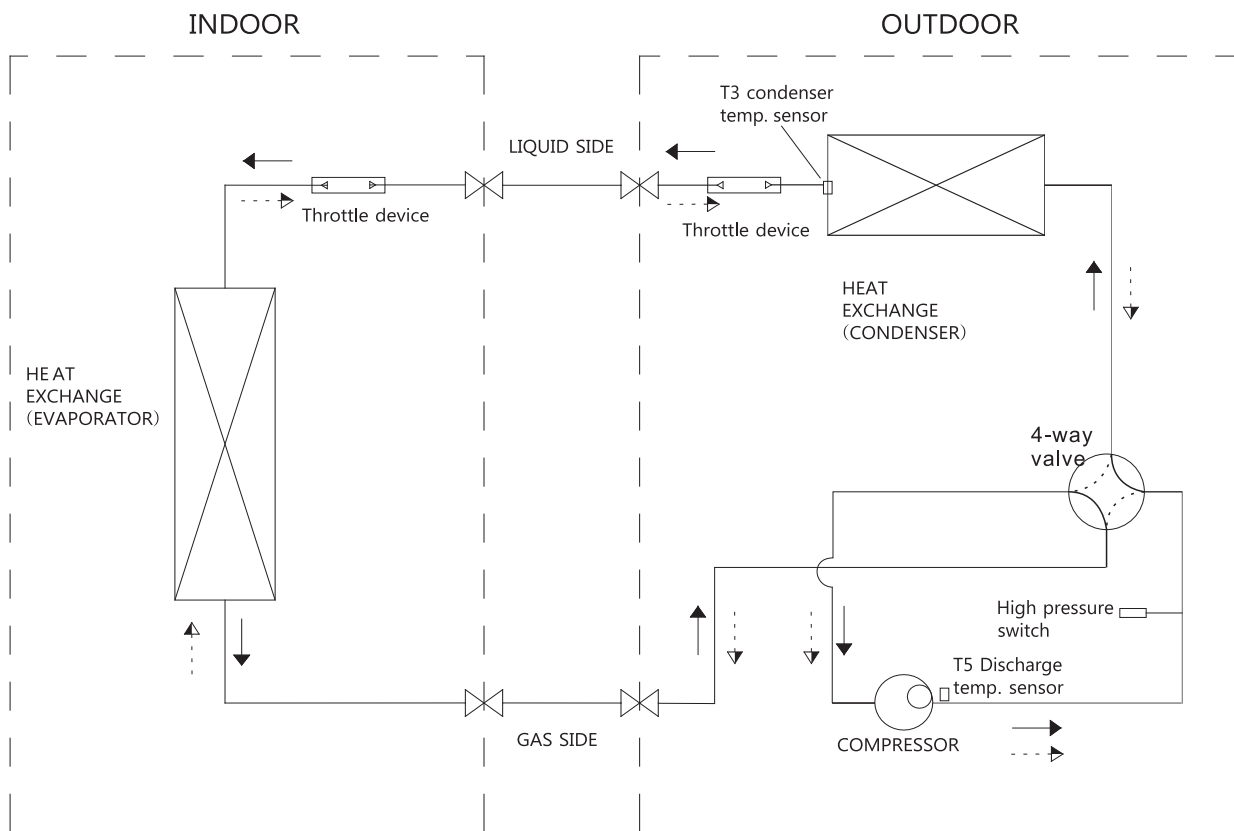

NOTE: In heating mode, the throttling device is outdoor unit piston. In cooling mode, the throttling device is indoor unit TXV or piston.

Applicable for 42k, 48k, 60k cooling only type

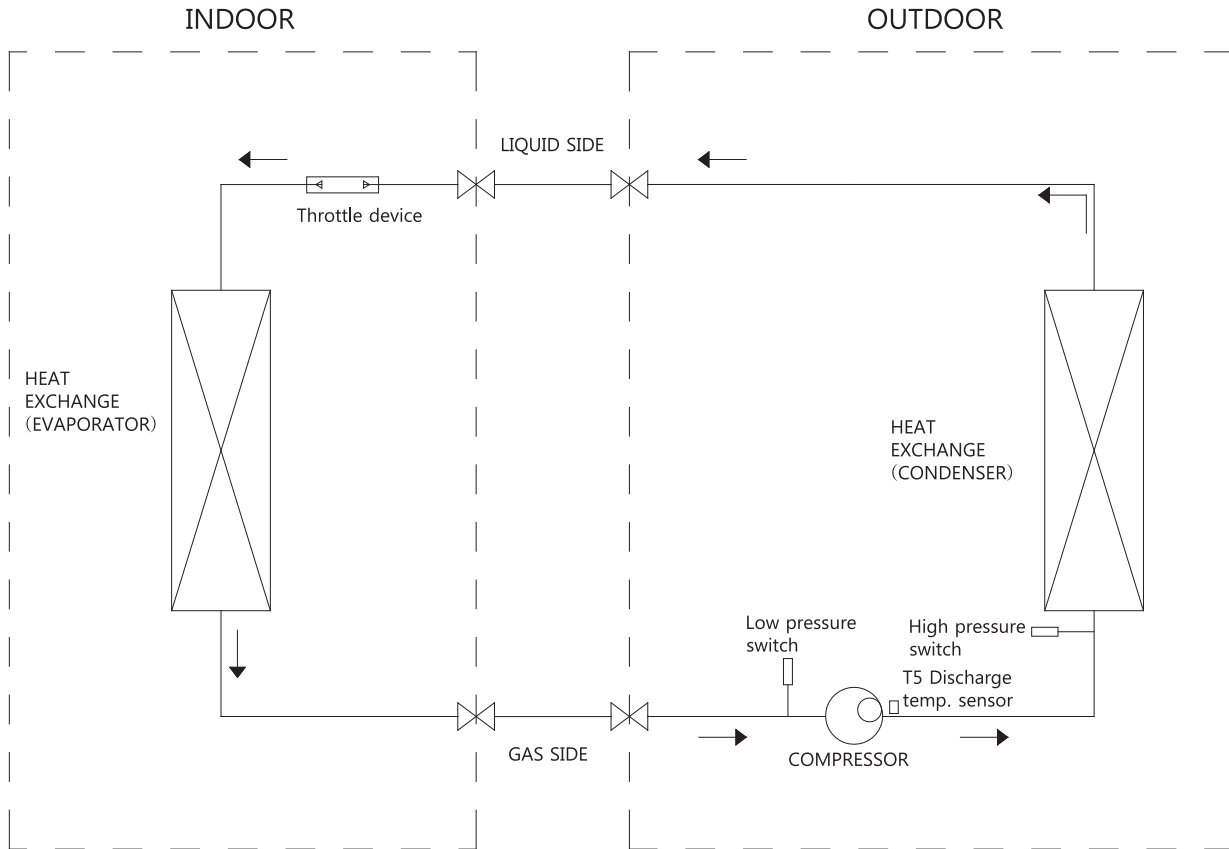

Applicable for 42k, 48k, 60k cooling & heating type

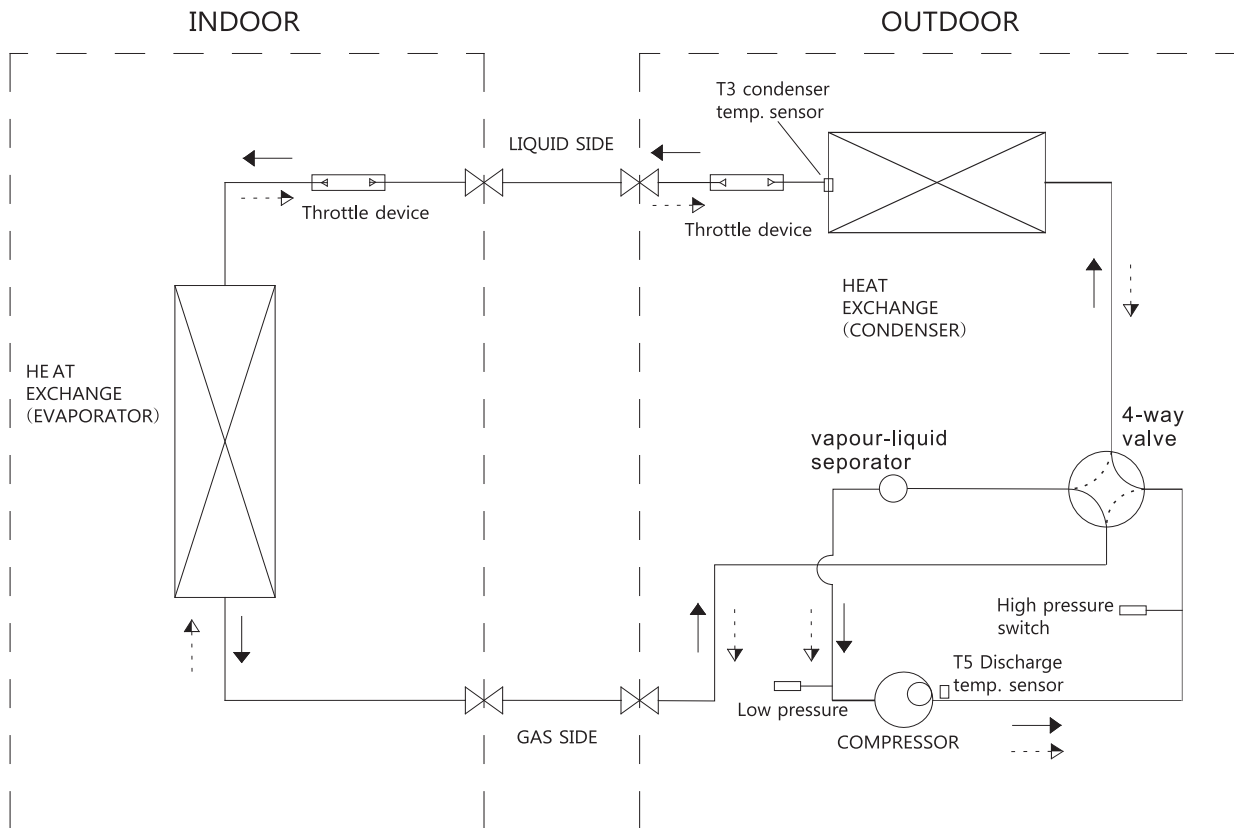

NOTE: In heating mode, the throttling device is outdoor unit piston. In cooling mode, the throttling device is indoor unit TXV or piston.

4. Wiring Diagrams

Applicable for 18k, 24k, 30k, 36k, 42k, 48k, 60k cooling only type

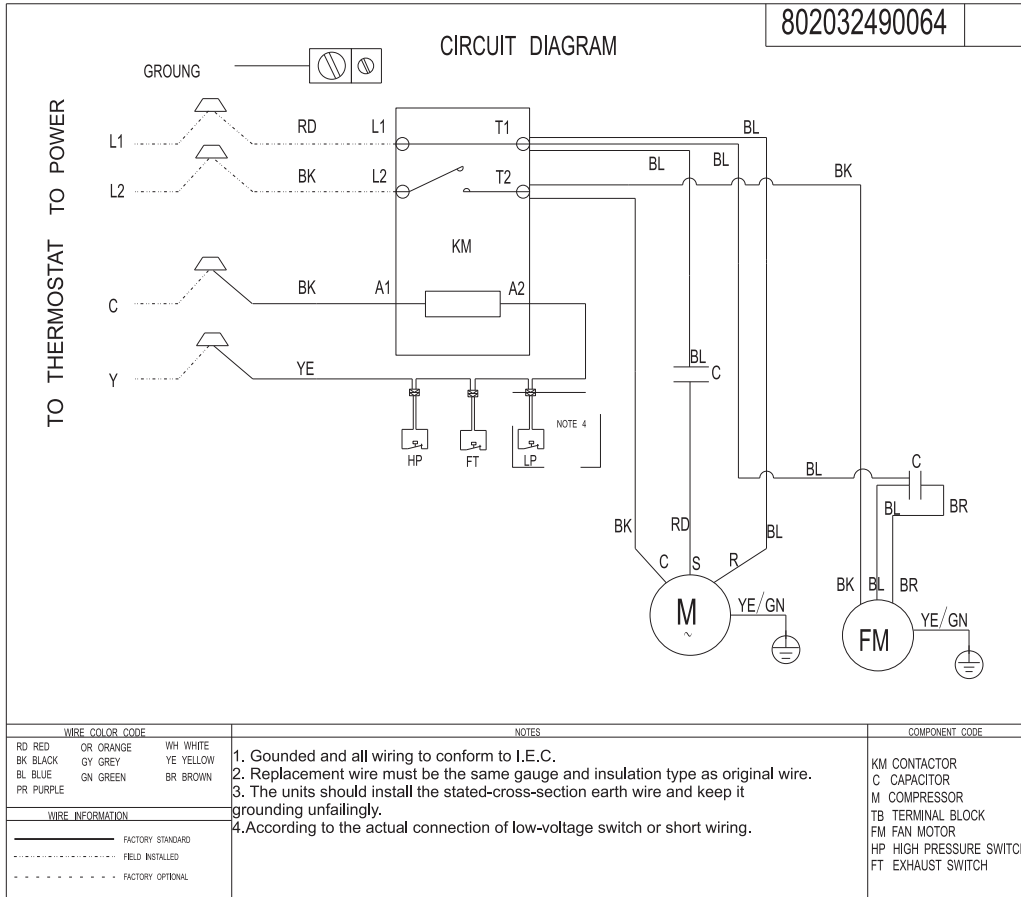

Applicable for 18k, 24k, 30k, 36k, 42k, 48k, 60k cooling & heating type

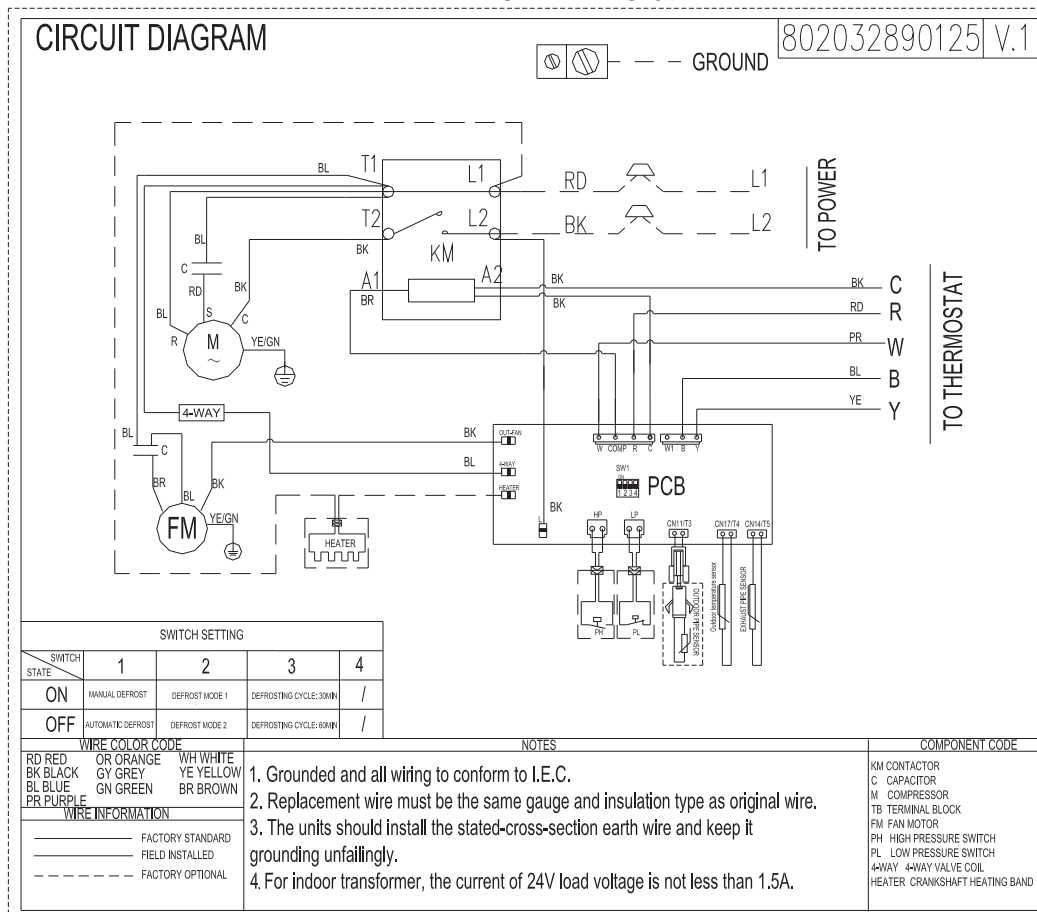

5. Electric Characteristics

Model	Power Supply				
	Hz	Phase	Voltage	Min.	Max.
18K	60	1	220-230V	198V	242V
24K	60	1	220-230V	198V	242V
30K	60	1	220-230V	198V	242V
36K	60	1	220-230V	198V	242V
42K	60	1	220-230V	198V	242V
48K	60	1	220-230V	198V	242V
60K	60	1	220-230V	198V	242V

6. Operation Limits

Mode \ Temperature	Cooling operation	Heating operation
Room temperature	63°F~86°F	63°F~86°F
Outdoor temperature	64°F~109°F	19°F~75°F

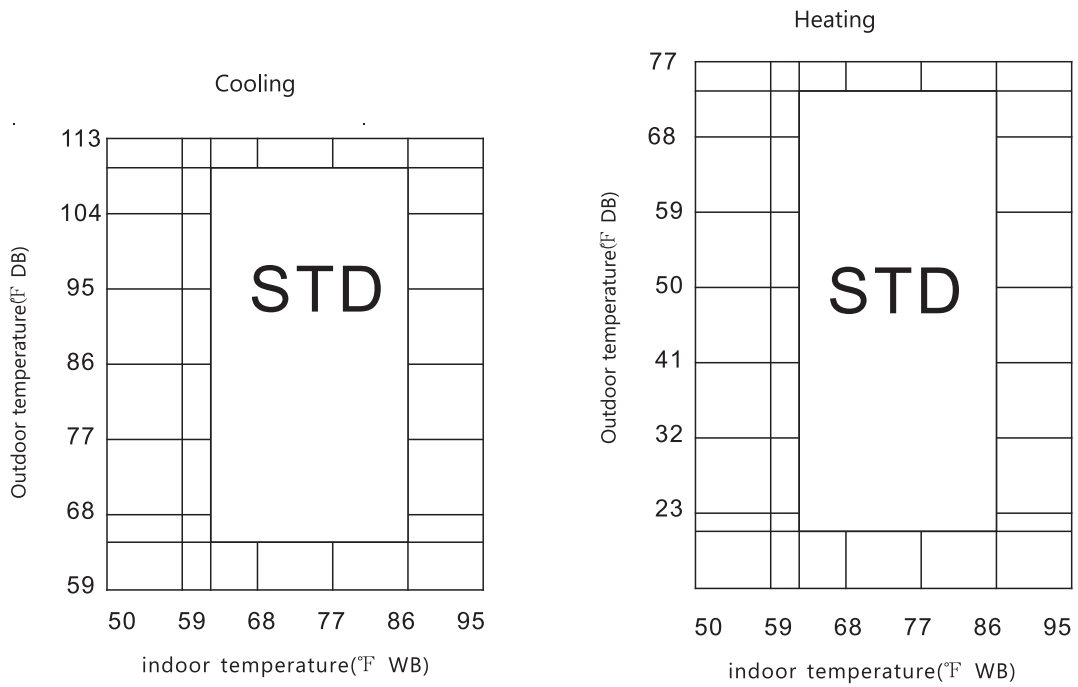

⚠ WARNING

When the ambient temperature is more than 109 °F, the booter is suggested to install in the outdoor unit from 18,000 ; 24,000 ; 30,000 and 36,000 Btu in order to shorten the restart time. Without it, the restart time may be around 15-20 minutes.

Installation

1.	Installation Procedure	11
2.	Location selection	12
3.	Outdoor unit installation (Top Discharge Unit)	13
4.	Refrigerant pipe installation	15
5.	Vacuum Drying and Leakage Checking	17
6.	Additional refrigerant charge	18
7.	Engineering of insulation	19
8.	Engineering of electrical wiring	20
9.	Test operation	22
10.	Trouble code table	23

1. Installation Procedure

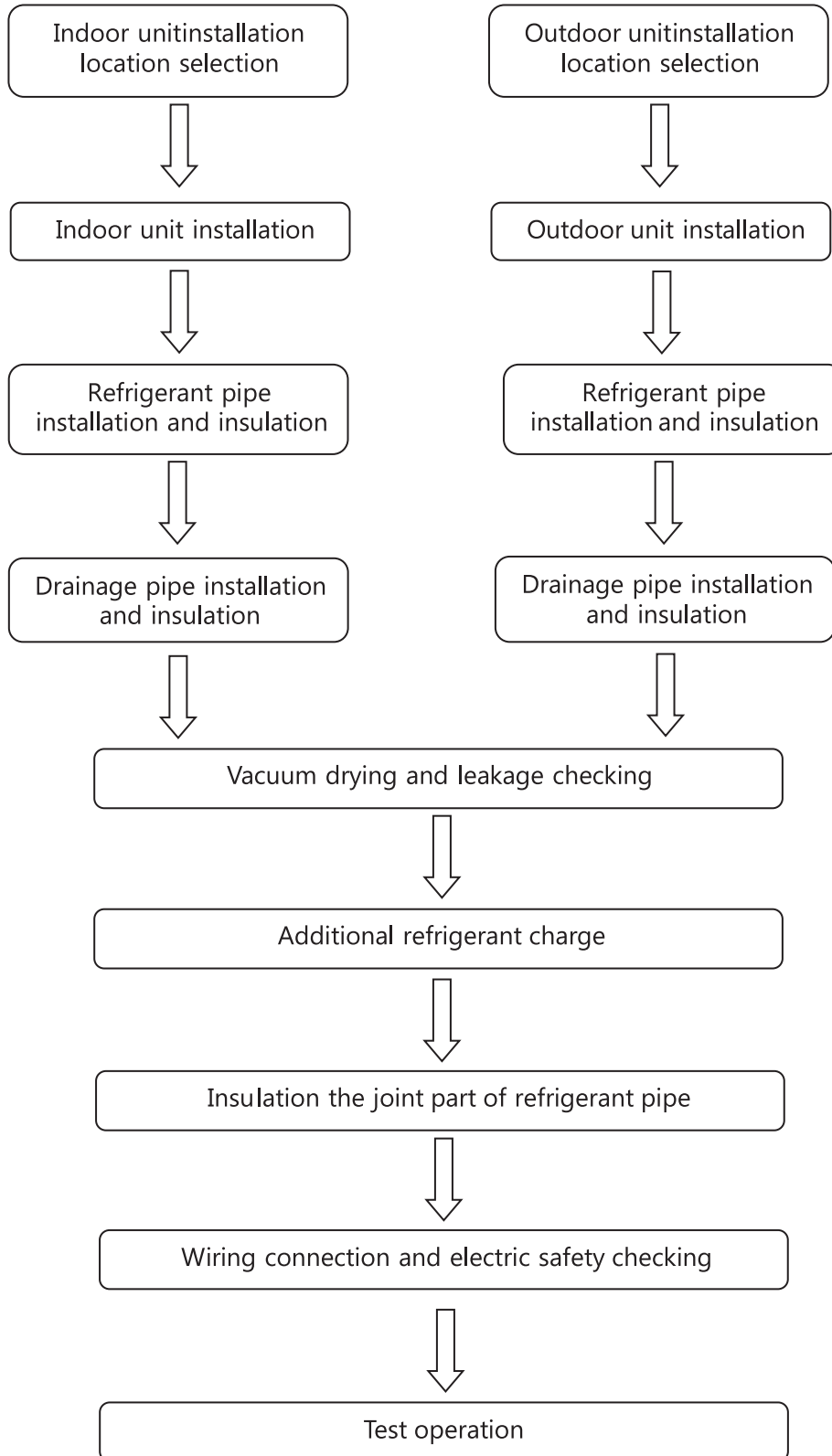

2. Location selection

2.1 Indoor unit location selection

- ⌚ The place shall easily support the indoor unit's weight
- ⌚ The place can ensure the indoor unit installation and inspection
- ⌚ The place can ensure the indoor unit horizontally installed.
- ⌚ The place shall allow easy water drainage.
- ⌚ The place shall easily connect with the outdoor unit.
- ⌚ The place where air circulation in the room should be good.
- ⌚ There should not be any heat source or steam near the unit.
- ⌚ There should not be any oil gas near the unit
- ⌚ There should not be any corrosive gas near the unit
- ⌚ There should not be any salty air near the unit
- ⌚ There should not be strong electromagnetic wave near the unit
- ⌚ There should not be inflammable materials or gas near the unit
- ⌚ There should not be strong voltage vibration.

2.2 Outdoor unit location selection

- ⌚ The place shall easily support the outdoor unit's weight.
- ⌚ Locate the outdoor unit as close to indoor unit as possible
- ⌚ The piping length and height drop can not exceed the allowable value.
- ⌚ The place where the noise, vibration and outlet air do not disturb the neighbors.
- ⌚ There is enough room for installation and maintenance.
- ⌚ The air outlet and the air inlet are not impeded, and not face the strong wind.
- ⌚ It is easy to install the connecting pipes and cables.
- ⌚ There is no danger of fire due to leakage of inflammable gas.
- ⌚ It should be a dry and well ventilation place
- ⌚ The support should be flat and horizontal
- ⌚ Do not install the outdoor unit in a dirty or severely polluted place, so as to avoid blockage of the heat exchanger in the outdoor unit.
- ⌚ If is built over the unit to prevent direct sunlight, rain exposure, direct strong wind, snow and other scraps accumulation, make sure that heat radiation from the condenser is not restricted.

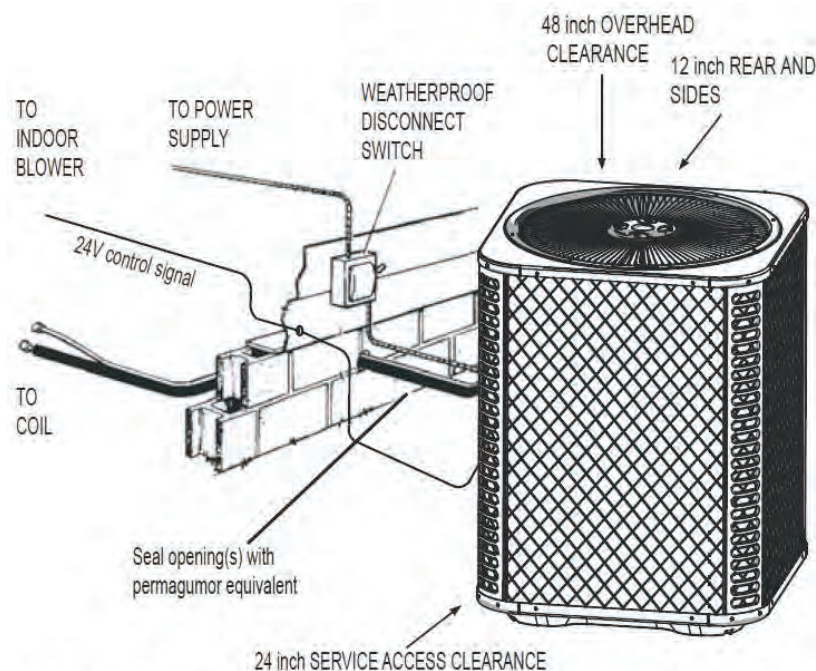

NOTE: All outdoor wiring must be weatherproof

3. Outdoor unit installation (Top Discharge Unit)

3.1 Location selection

Before starting the installation, select and check the suitability of the location for both the indoor and outdoor unit. Observe all limitations and clearance requirements. The outdoor unit must have sufficient clearance for air entrance to the condenser coil, for air discharge and for service access.

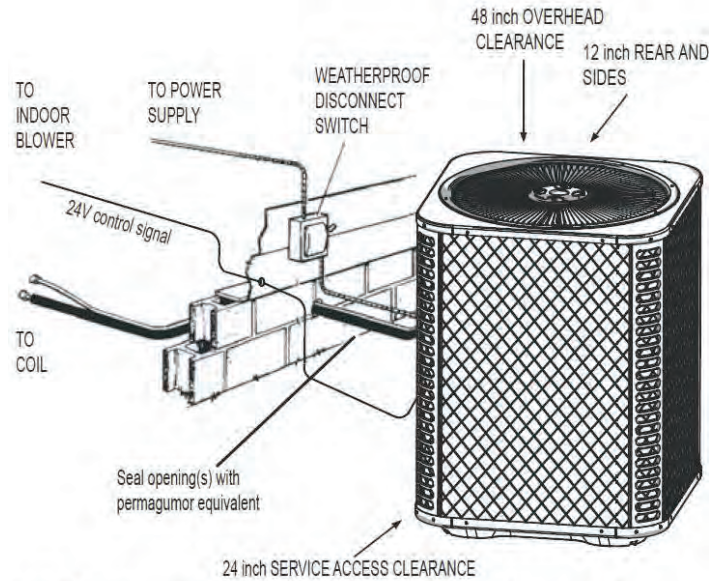

NOTE:All outdoor wiring must be weatherproof

Note: For multiple unit installations, units must be spaced a minimum of 18 inches apart. (Coil face to coil face.)

If the unit is to be installed on a hot sun exposed roof or a black-topped ground area, the unit should be raised sufficiently above the roof or ground to avoid taking the accumulated layer of hot air into the outdoor unit.

Provide an adequate structural support.

3.2 Service space for outdoor unit

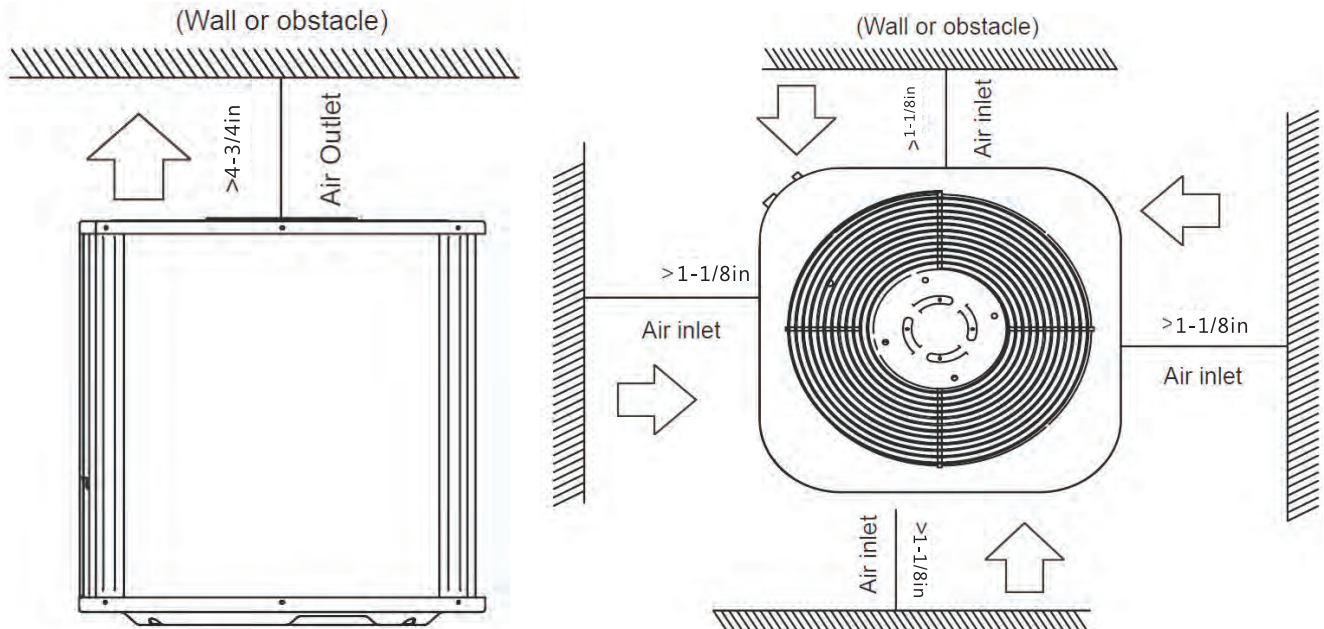

3.3 Install the Unit

On ground installation

The unit may be installed at ground level on a solid base that will not shift or settle, causing strain on the refrigerant lines and possible leaks. Maintain the clearances shown in Fig.5 and install the unit in a level position.

Normal operating sound levels may be objectionable if the unit is placed directly under windows of certain rooms (bedrooms, study, etc).

Top of unit discharge area must be unrestricted for at least 6 feet above the unit.

Warning: The outdoor unit should not be installed in an area where mud or ice could cause personal injury. Elevate the unit sufficiently to prevent any blockage of the air entrances by snow in areas where there will be snow accumulation. Check the local weather bureau for the expected snow accumulation in your area. Isolate the unit from rain gutters to avoid any possible wash out of the foundation.

On roof installation

When installing units on a roof, the structure must be capable of supporting the total weight of the unit, including a padded frame unit, rails, etc., which should be used to minimize the transmission of sound or vibration into the conditioned space.

4. Refrigerant pipe installation

4.1 Maximum pipe length and height drop

Considering the allowable pipe length and height drop to decide the installation position. Make sure the distance and height drop between indoor and outdoor unit not exceeded the data in the following table.

Model	Max. Length FT[M]	Max. Elevation FT[M]	Max elbow(pcs)
≤36,000Btu/h	50[15]	26[8]	5
>36,000Btu/h	66[20]	33[10]	5

4.2 The procedure of connecting pipes

4.2.1 Choose the pipe size according to the specification table.

4.2.2 Confirm the cross way of the pipes.

4.2.3 Measure the necessary pipe length.

4.2.4 Cut the selected pipe with pipe cutter

⌚ Make the section flat and smooth.

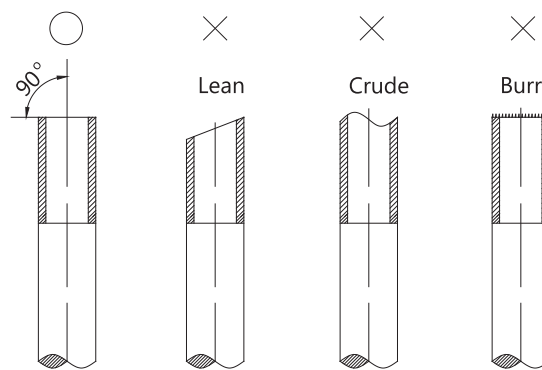

4.2.5 Insulate the copper pipe

⌚ Before test operation, the joint parts should not be heat insulated.

4.2.6 Drill holes if the pipes need to pass the wall.

4.2.7 According to the field condition to bend the pipes so that it can pass the wall smoothly.

4.2.8 Bind and wrap the wire together with the insulated pipe if necessary.

4.2.9 Set the wall conduit

4.2.10 Set the supporter for the pipe.

4.2.11 Locate the pipe and fix it by supporter

⌚ For horizontal refrigerant pipe, the distance between supporters should not be exceed 1m.

⌚ For vertical refrigerant pipe, the distance between supporters should not be exceed 1.5m.

4.2.14 Connect the pipe to indoor unit and outdoor unit by brazing (Top discharge outdoor unit and Air Handler indoor units)

⌚ Top discharge outdoor unit and air handler indoor units connections are copper-to-copper and should be brazed with a phosphorous-copper alloy material such as Silfos -5 or equivalent. DO NOT use soft solder. The outdoor units have reusable service valves on both the liquid and vapor connections. The total system refrigerant charge is retained within the outdoor unit during shipping and installation. The reusable service valves are provided to evacuate and charge per this instruction.

⌚ Serious service problems can be avoided by taking adequate precautions to assure an internally clean and dry system.

CAUTION: Dry nitrogen should always be supplied through the tubing while it is being brazed, because the temperature required is high enough to cause oxidation of the copper unless an inert atmosphere is provide. The flow of dry nitrogen should continue until the joint has cooled. Always use a pressure regulator and safety valve to insure that only low pressure dry nitrogen is introduced into the tubing. Only a small flow is necessary to displace air and prevent oxidation.

- ⌚ Precautions should be taken to prevent heat damage to service valve by wrapping a wet rag around it as shown in following picture. Also, protect all painted surfaces, insulation, during brazing. After brazing cool joint with wet rag.
- ⌚ Valve can be opened by removing the plunger cap and fully inserting a hex wrench into the stem and backing out counter-clockwise until valve stem just touches the chamfered retaining wall.

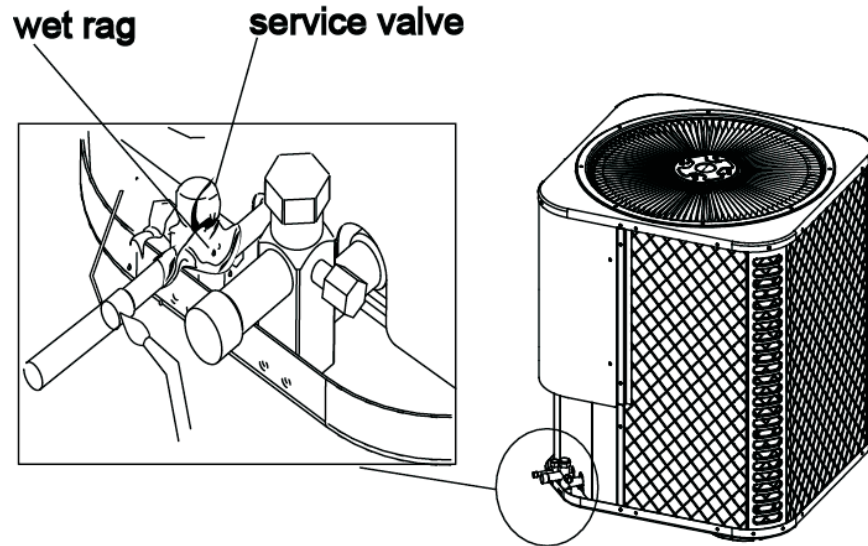

5. Vacuum Drying and Leakage Checking

5.1 Purpose of vacuum drying

- ① Eliminating moisture in system to prevent the phenomena of ice-blockage and copper oxidation. Ice-blockage shall cause abnormal operation of system, while copper oxide shall damage compressor.
- ② Eliminating the non-condensable gas (air) in system to prevent the components oxidizing, pressure fluctuation and bad heat exchange during the operation of system.

5.2 Selection of vacuum pump

- ① The ultimate vacuum degree of vacuum pump shall be -756mmHg or above.
- ② Precision of vacuum pump shall reach 0.02mmHg or above.

5.3 Operation procedure for vacuum drying

Due to different construction environment, two kinds of vacuum drying ways could be chosen, namely ordinary vacuum drying and special vacuum drying.

5.3.1 Ordinary vacuum drying

1. When conduct first vacuum drying, connect pressure gauge to the infusing mouth of gas pipe and liquid pipe, and keep vacuum pump running for 1 hour (vacuum degree of vacuum pump shall be reached -755mmHg).
2. If the vacuum degree of vacuum pump could not reach -755mmHg after 1 hour of drying, it indicates that there is moisture or leakage in pipeline system and need to go on with drying for half an hour.
3. If the vacuum degree of vacuum pump still could not reach -755mmHg after 1.5 hours of drying, check whether there is leakage source.
4. Leakage test : After the vacuum degree reaches -755mmHg, stop vacuum drying and keep the pressure for 1 hour. If the indicator of vacuum gauge does not go up, it is qualified. If going up, it indicates that there is moisture or leak source.

5.3.2 Special vacuum drying

The special vacuum drying method shall be adopted when:

1. Finding moisture during flushing refrigerant pipe.
2. Conducting construction on rainy day, because rain water might penetrate into pipeline.
3. Construction period is long, and rain water might penetrate into pipeline.
4. Rain water might penetrate into pipeline during construction.

Procedures of special vacuum drying are as follows:

1. Vacuum drying for 1 hour.
2. Vacuum damage, filling nitrogen to reach 0.5Kgf/cm².
Because nitrogen is dry gas, vacuum damage could achieve the effect of vacuum drying, but this method could not achieve drying thoroughly when there is too much moisture. Therefore, special attention shall be drawn to prevent the entering of water and the formation of condensate water.
3. Vacuum drying again for half an hour.
If the pressure reached -755mmHg, start to pressure leakage test. If it can not reach the value, repeat vacuum damage and vacuum drying again for 1 hour.
4. Leakage test : After the vacuum degree reaches -755mmHg, stop vacuum drying and keep the pressure for 1 hour. If the indicator of vacuum gauge does not go up, it is qualified. If going up, it indicates that there is moisture or leak source.

6. Additional refrigerant charge

- ⌚ After the vacuum drying process is carried out, the additional refrigerant charge process need to be performed.
- ⌚ The outdoor unit is factory charged with refrigerant. The additionalrefrigerant charge volume is decided by the diameter and length of the liquid pipbetween indoorand outdoorunit. Refer the following formula tocalculate the charge volume.

Diameter of liquid pipe (IN [mm])	1/4 [6.35]	3/8[9.52]	1/4[12.7]
Formula	$V=0.22\text{ oz} \times (L-16)$	$V=0.43\text{ oz} \times (L-16)$	$V=0.64\text{ oz} \times (L-16)$

V: Additional refrigerantcharge volume (oz).

L : The length of the liquid pipe (ft).

Note:

- ⌚ Refrigerant may only be charged after performed the vacuum drying process
- ⌚ Always use gloves and glasses to protect your hands and eyes during the charge work.
- ⌚ Use electronic scale or fluid infusion apparatus to weight refrigerant to be recharged. Be sure to avoid extra refrigerant charged, it may cause liquid hammerof the compressor or protections
- ⌚ Use supplementing flexible pipe to connect refrigerant cylinder, pressure gauge and outdoor unit. And The refrigerant should be charged inliquid state. Before recharging, The air in the flexible pipe and manifold gauge should be exhausted.
- ⌚ After finished refrigerant recharge process, check whether there is refrigerant leakage at the connection joint part.(Using gas leak age detector or soap water to detect).

7. Engineering of insulation

7.1 Insulation of refrigerant pipe

7.1.1 Operational procedure of refrigerant pipe insulation

Cut the suitable pipe → insulation (except joint section) → flare the pipe → piping layout and connection → vacuum drying → insulate the joint parts

7.1.2 Purpose of refrigerant pipe insulation

- ⌚ During operation, temperature of gas pipe and liquid pipe shall be over-heating or over-cooling extremely. Therefore, it is necessary to carry out insulation; otherwise it shall debase the performance of unit and burn compressor.
- ⌚ Gas pipe temperature is very low during cooling. If insulation is not enough, it shall form dew and cause leakage.
- ⌚ Temperature of gas pipe is very high (generally 50-100°C) during heating. Insulation work must be carried out to prevent hurt by carelessness touching.

7.1.3 Insulation material selection for refrigerant pipe

- ⌚ The burning performance should be over 120°C
- ⌚ According to the local law to choose insulation materials
- ⌚ The thickness of insulation layer shall be above 10mm. If in hot or wet environment place, the layer of insulation should be thicker accordingly.

7.1.4 Installation highlights of insulation construction

- ⌚ Gas pipe and liquid pipe shall be insulated separately, if the gas pipe and liquid pipe were insulated together; it will decrease the performance of air conditioner.

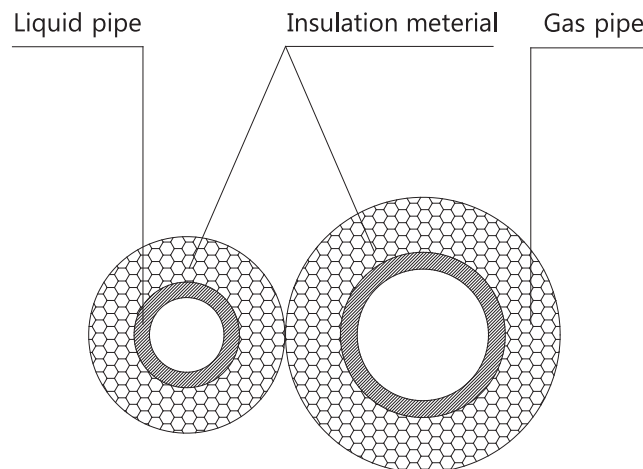

- ⌚ The insulation material at the joint pipe shall be 5~10cm longer than the gap of the insulation material.
- ⌚ The insulation material at the joint pipe shall be inserted into the gap of the insulation material.
- ⌚ The insulation material at the joint pipe shall be banded to the gap pipe and liquid pipe tightly.
- ⌚ The linking part should be used glue to paste together
- ⌚ Be sure not to bind the insulation material over-tight, it may extrude out the air in the material to cause bad insulation and cause easy aging of the material.

7.2 Insulation of drainage pipe

7.2.1 Operational procedure of refrigerant pipe insulation

Select the suitable pipe → insulation (except joint section) → piping layout and connection → drainage test → insulate the joint parts

7.2.2 Purpose of drainage pipe insulation

The temperature of condensate drainage water is very low. If insulation is not enough, it shall form dew and cause leakage to damage the house decoration.

7.2.3 Insulation material selection for drainage pipe

- ⌚ The insulation material should be flame retardant material, the flame retardant of the material should be selected according to the local law.
- ⌚ Thickness of insulation layer is usually above 10mm.
- ⌚ Use specific glue to paste the seam of insulation material, and then bind with adhesive tape. The width of tape shall not be less than 5cm. Make sure it is firm and avoid dew

7.2.4 Installation and highlights of insulation construction

- ⌚ The single pipe should be insulated before connecting to another pipe, the joint part should be insulated after the drainage test.
- ⌚ There should be no insulation gap between the insulation material.

8. Engineering of electrical wiring

8.1 Highlights of electrical wiring installation

- ⌚ All field wiring construction should be finished by qualified electrician.
- ⌚ Air conditioning equipment should be grounded according to the local electrical regulations.
- ⌚ Current leakage protection switch should be installed.
- ⌚ Do not connect the power wire to the terminal of signal wire.
- ⌚ When power wire is parallel with signal wire, put wires to their own wire tube and remain at least 300mm gap.
- ⌚ According to table in indoor part named "the specification of the power" to choose the wiring, make sure the selected wiring not small than the data showing in the table.
- ⌚ Select different colors for different wire according to relevant regulations.
- ⌚ Do not use metal wire tube at the place with acid or alkali corrosion, adopt plastic wire tube to replace it.
- ⌚ There must be not wire connect joint in the wire tube If joint is a must, set a connection box at the place.
- ⌚ The wiring with different voltage should not be in one wire tube.
- ⌚ Ensure that the color of the wires of outdoor and the terminal No. are same as those of indoor unit respectively.

8.2 ELECTRIC WIRING GAUGE

Model (cooling only type)			18K	24K	30K	36K	42K	48K	60K
Line Gauge	Indoor Unit Power Line	Line Quantity	3	3	3	3	3	3	3
		Line Diameter(AWG)	16	16	16	16	16	16	16
	Outdoor Unit Power Line	Line Quantity	3	3	3	3	3	3	3
		Line Diameter(AWG)	14	14	12	12	10	10	10
	Outdoor-Indoor Singal Line	Line Quantity	2	2	2	2	2	2	2
		Line Diameter(AWG)	18	18	18	18	18	18	18
	Thermostat Singal Line	Line Quantity	4	4	4	4	4	4	4
		Line Diameter(AWG)	18	18	18	18	18	18	18

Model (cooling & heating type)			18K	24K	30K	36K	42K	48K	60K
Line Gauge	Indoor Unit Power Line	Line Quantity	3	3	3	3	3	3	3
		Line Diameter(AWG)	16	16	16	16	16	16	16
	Outdoor Unit Power Line	Line Quantity	3	3	3	3	3	3	3
		Line Diameter(AWG)	14	14	12	12	10	10	10
	Outdoor-Indoor Singal Line	Line Quantity	2	2	2	2	2	2	2
		Line Diameter(AWG)	18	18	18	18	18	18	18
	Thermostat Singal Line	Line Quantity	6	6	6	6	6	6	6
		Line Diameter(AWG)	18	18	18	18	18	18	18

9. Test operation

9.1 The test operation must be carried out after the entire installation has been completed.

9.2 Please confirm the following points before the test operation.

- ⌚ The indoor unit and outdoor unit are installed properly.
- ⌚ Tubing and wiring are correctly completed.
- ⌚ The refrigerant pipe system is leakage-checked.
- ⌚ The drainage is unimpeded.
- ⌚ The ground wiring is connected correctly.
- ⌚ The length of the tubing and the added stow capacity of the refrigerant have been recorded.
- ⌚ The power voltage fits the rated voltage of the air conditioner.
- ⌚ There is no obstacle at the outlet and inlet of the outdoor and indoor units.
- ⌚ The gas-side and liquid-side stop valves are both opened.
- ⌚ The air conditioner is pre-heated by turning on the power.

9.3 Test operation

Set the air conditioner under the mode of "COOLING" by remote controller, and check the following points.

Indoor unit

- ⌚ Whether the switch on the remote controller works well.
- ⌚ Whether the buttons on the remote controller works well.
- ⌚ Whether the air flow louver moves normally.
- ⌚ Whether the room temperature is adjusted well.
- ⌚ Whether the indicator lights normally.
- ⌚ Whether the temporary buttons works well.
- ⌚ Whether the drainage is normal.
- ⌚ Whether there is vibration or abnormal noise during operation.

Outdoor unit

- ⌚ Whether there is vibration or abnormal noise during operation.
- ⌚ Whether the generated wind, noise, or condensed of by the air conditioner have influenced your neighborhood.
- ⌚ Whether any of the refrigerant is leaked.

10. Trouble code table

Display content		State description
No alarm: green light flashes Yellow lights	Green light slow flash	Normal standby
	Green light normally on	Normal operation
System Alarm: Green light slow flash Yellow light flashing	(T3)Temperature sensor fault	Yellow light flashes 2 times every 8 seconds
	(T5)Temperature sensor fault	Yellow light flashes 8 times every 8 seconds
	Low air pressure alarm	Yellow light flashes 6 times every 8 seconds
	High pressure alarm	Yellow light flashes 1 times every 8 seconds
	(T3)High temperature protection	Yellow light flashes 9 times every 8 seconds
	High exhaust temperature protection	Yellow light flashes 5 times every 8 seconds
System lock: Green light go out Yellow light normally on	3 high/low voltage protection in 20 minutes	It needs to be reenergized and it needs to work
	Exhaust temperature is too high for 3 times within 20 minutes	
	T3 high temperature protection 3 times within 20 minutes	

